



MAKE GLASS
FORWARD



**THE INVESTMENT
OF TODAY-**

**FOR THE SUCCESS OF
TOMORROW!**

GC-LDW

VERTICAL CNC MILLING AND DRILLING CENTER

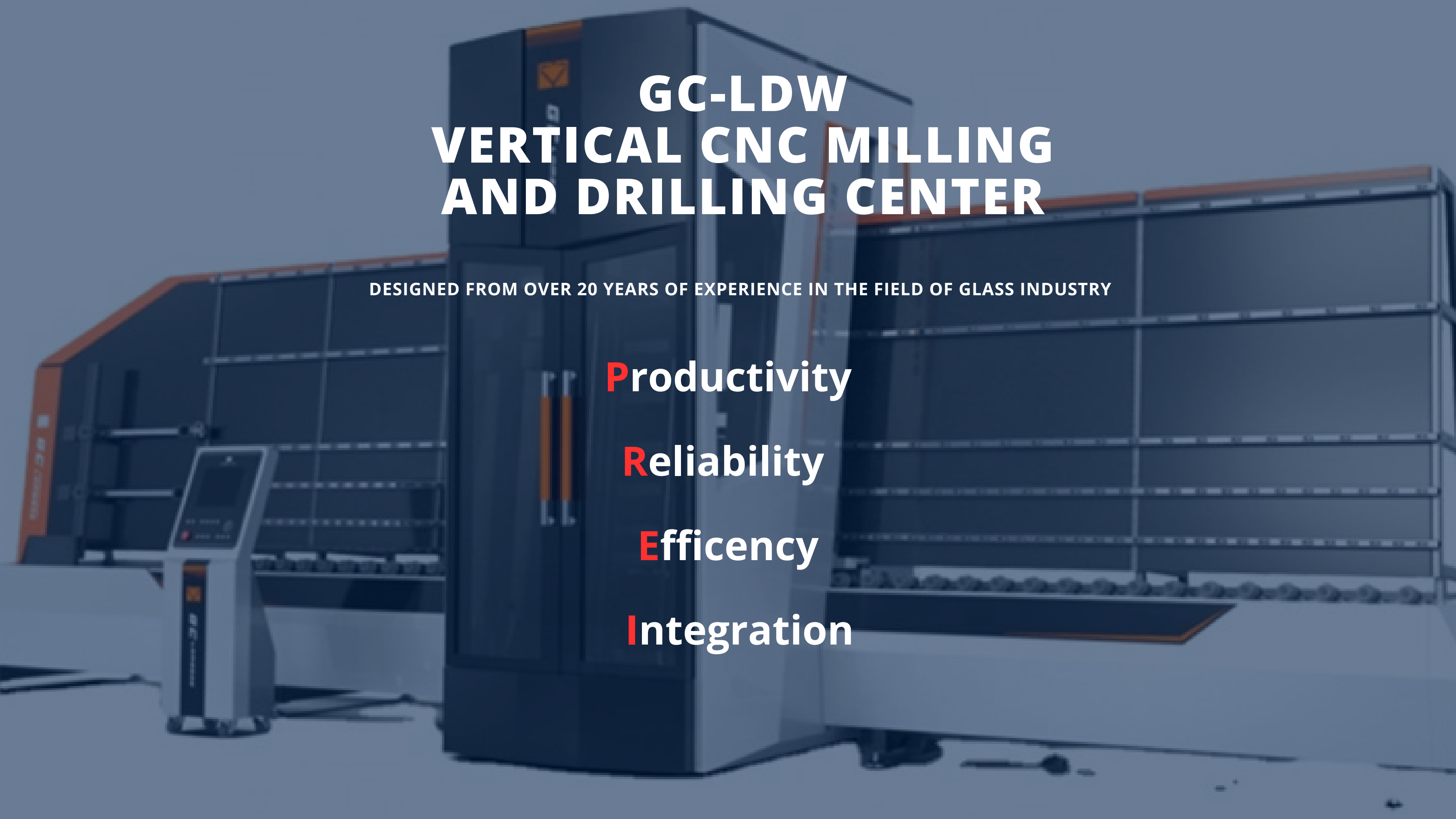

GC-LDW VERTICAL CNC MILLING AND DRILLING CENTER

DESIGNED FROM OVER 20 YEARS OF EXPERIENCE IN THE FIELD OF GLASS INDUSTRY

Productivity

Reliability

Efficiency

Integration

APPLICATION



mirrors | photovoltaic | doors | ovens and hob tops

Technological.

Original.

Performing solutions.

TOP machines for glass processing.



shower doors enclosures | ventilated façades and windows | stairs | tables

Vertical CNC milling and drilling centers

GC-LDW CAN PERFORM MULTIPLE MACHINING PROCESSES

GC-LDW can carry out arrising, polishing, grinding, milling and drilling operations.

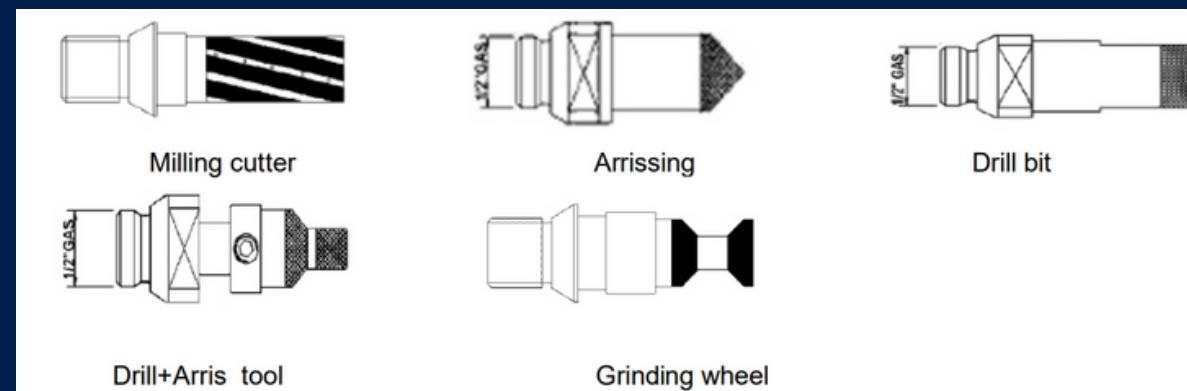

- possibility to work both rectangular and shaped glass sheets (two rectilinear side required)
- two coaxial opposed electrospindles and tool cooling system with internal and external water, which enables a higher finishing and machining quality
- two 8+8 tool mangzines installed on a carriage fixed to the electrospindle, ensure tool change operations in the shortest time



KEY BUYER BENEFITS

- + **10s** tool change times: two 8 + 8 position tool magazines fixed integrally with the vertical carriage. The tool change operation takes just 10s regardless of the processing area.
- + **2,000** RPM spindle speed with torque output 25Nm

+ **5 axis:** X, Y, V, Z, W linear axis are driven by high precision ball screw and slip on the linear slide way. X-axis controls the glass forward or backward, Y and V axis control the up and down movement of the two Spindles, Z and W axis controls the spindle to take or release the tool.

+ **Customized:** available in 3 standard sizes, it allows the processing of small and large-sized sheets up to 6,000 x 3,000mm max. (additional maximum processable sizes available upon request).

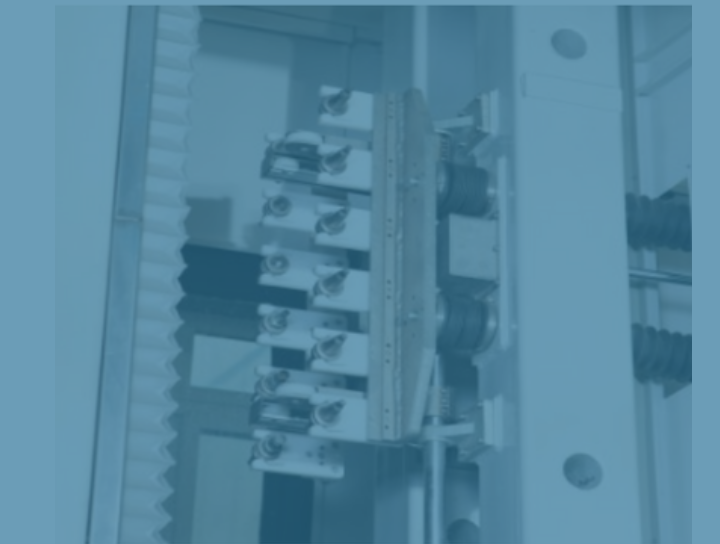
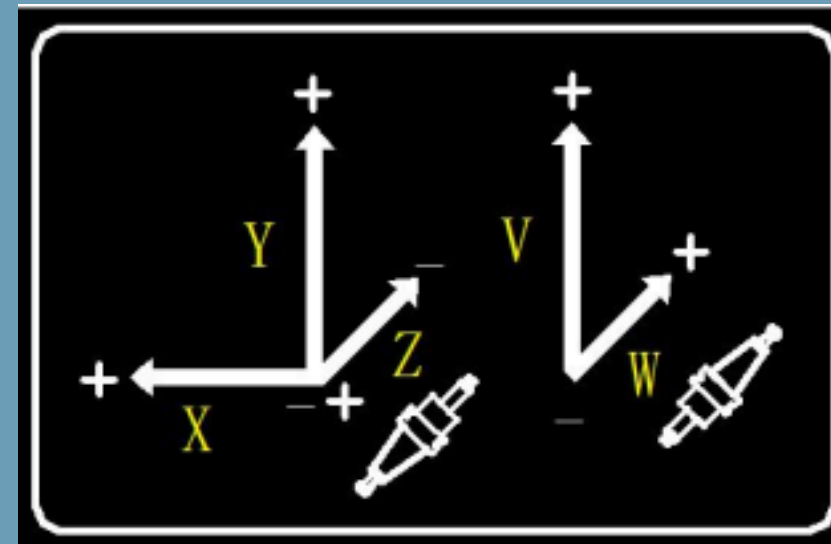
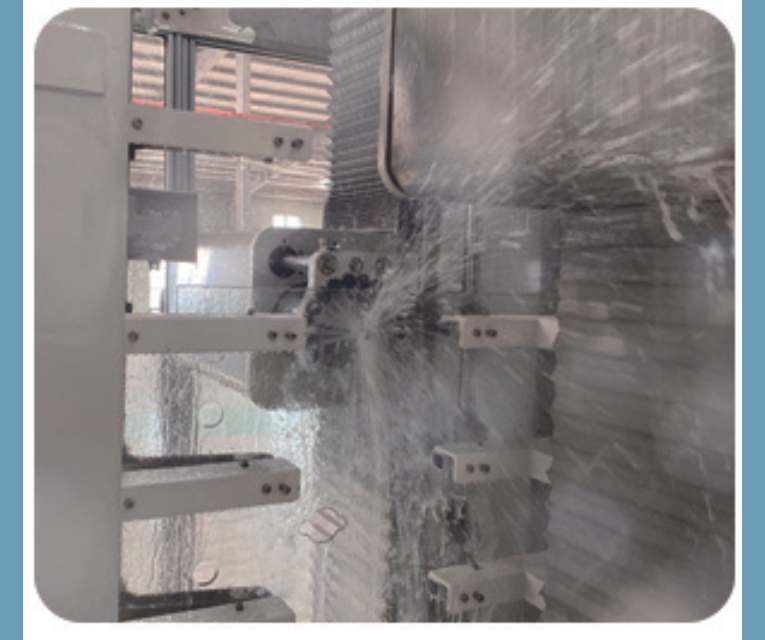

SOFTWARE AND USER INTERFACE

USING A CNC HAS BEEN SO STRAIGHT FORWARD!

THE SOFTWARE HAS BEEN DESIGNED TO MAXIMIZE THE NUMERICAL CONTROL AND USER INTERFACE EFFICIENCY.

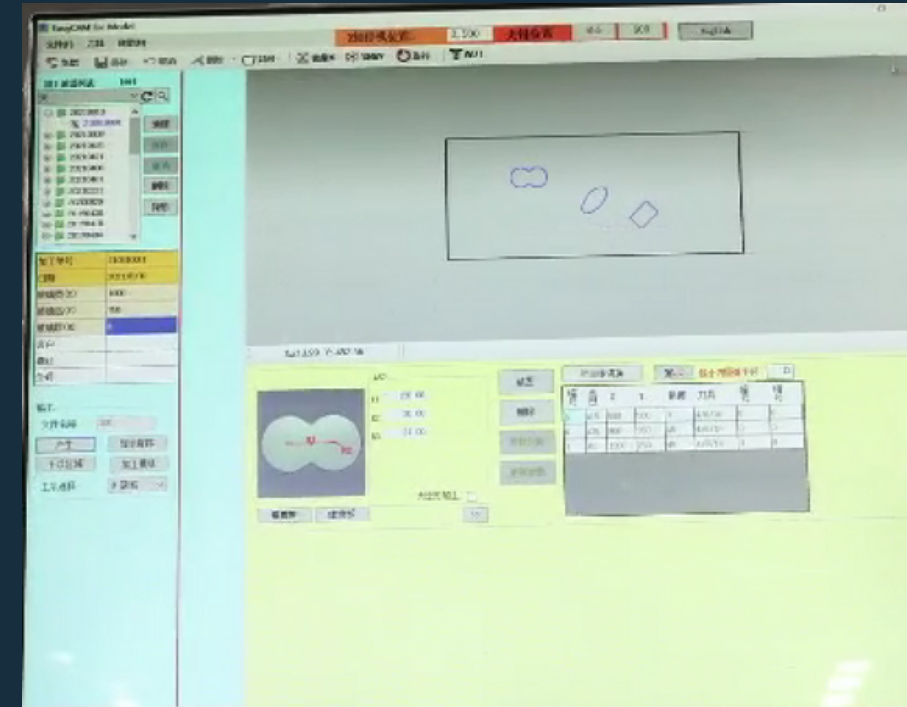

EVERYTHING UNDER CONTROL

Software experts have created a Easy CAM (GC) software that allows to monitor and supervise all the main components of the machine thanks to specific overviews.

PEACE OF MIND FOR DESIGNERS AND OPERATORS

The operator designing the workpiece just needs to select the necessary processing operations, and GC-LDW will take care of finding the right tool (if installed on the machine).

KEY BUYER BENEFITS

+ **-15%** time saved to grind a sheet with polished edges, using two spindles instead of one.

+ **-53%** time needed to identify a potential collision issue, thanks to the new interface.

+ **54 shapes** in graphic bank, and also can input your own CAD drawing for processing

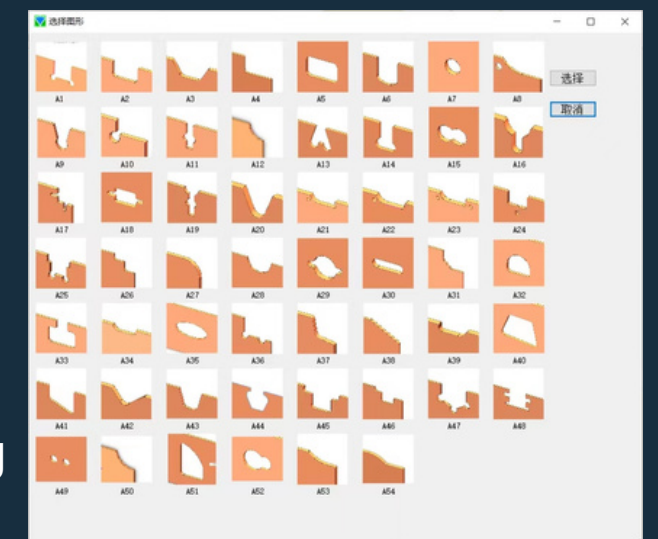

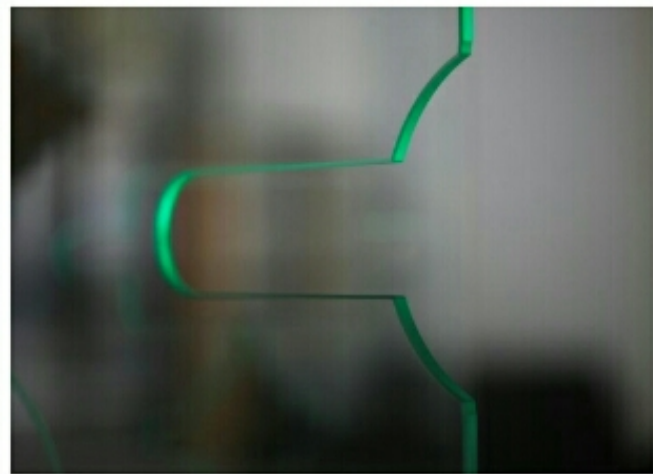
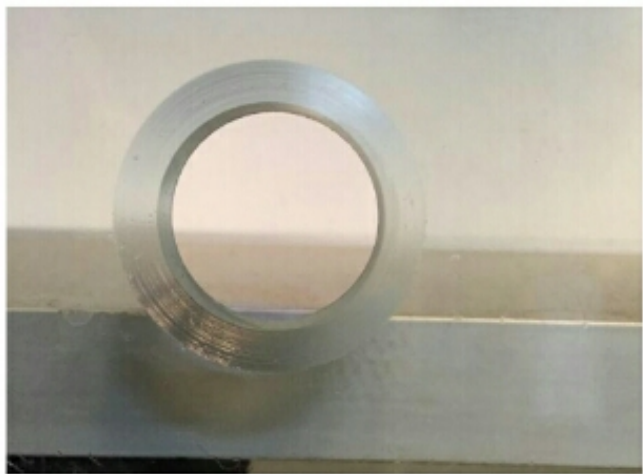
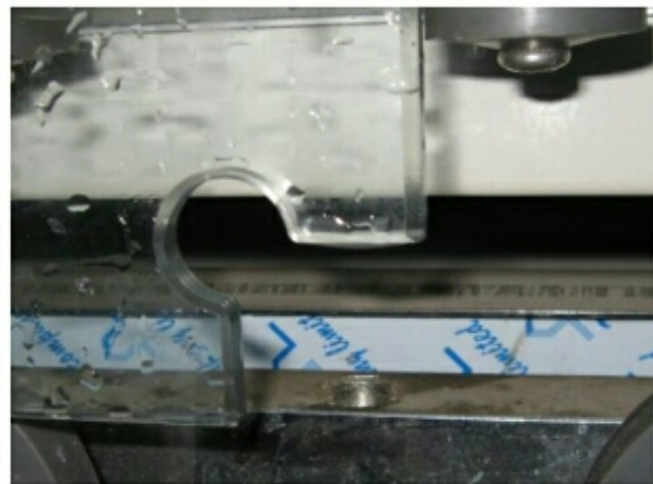
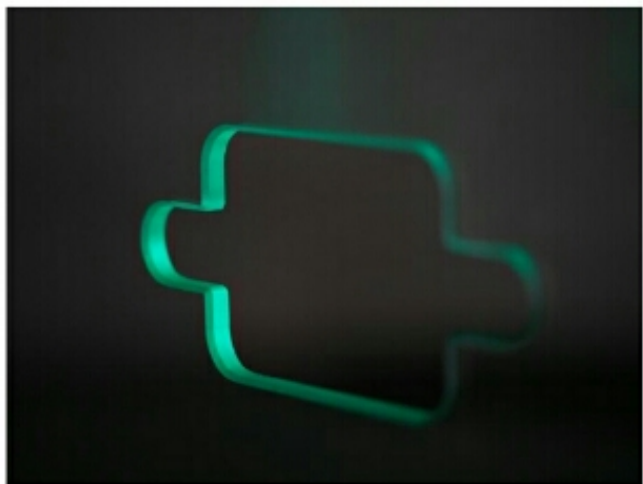
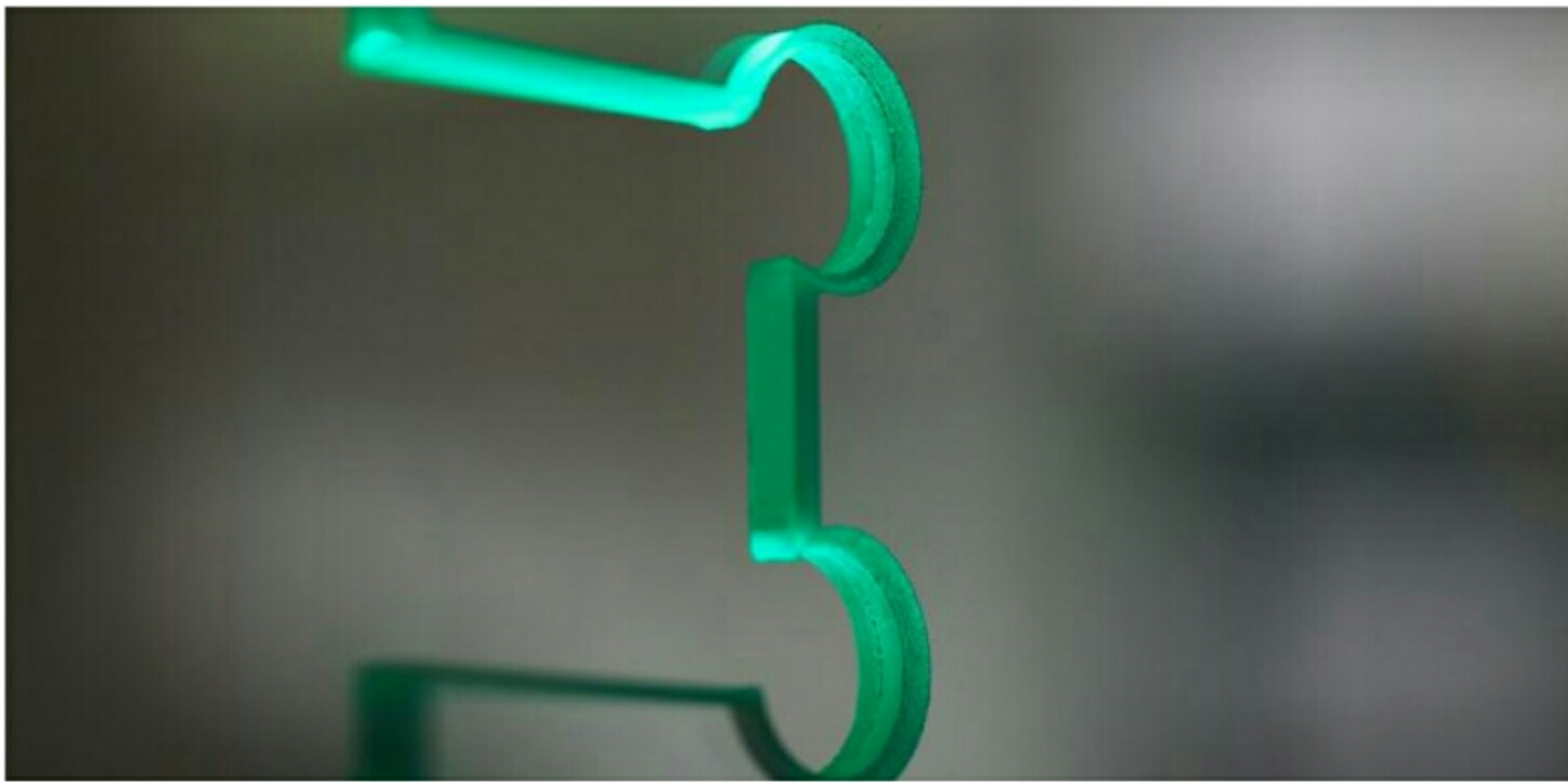



SERVICE

WE RESPOND TO YOUR CONCERNS QUICKLY

... you can depend on us

Count on Services which help you in the long run: to create optimal conditions for a successful production, or to get the most out of your vertical CNC center.

- World-wide technical support – 30+ service technicians
- Fast support for handling errors
- High education and quality standard of service technicians
- Guarantee supply of spare parts
- Personal service manager



EMAIL ADDRESS

info@hhglassmachinery.com



PHONE NUMBER

+86 1 32 56 88 49 39



WEBSITE

www.hhglassmachinery.com



THANK YOU!!



MAKE GLASS
FORWARD

YOUR PARTNER FOR GLASS PROCESSING SOLUTION